



Homozygosity for Robertsonian Translocation (14q;15q) in a Newborn with a Familial History of Recurrent Abortion and Newborns Affected by Hepatosplenomegaly: A Case Report

Sahra Sahraeean¹, Asiyeh Jebelli², Zahra Shahbazi³, Fahimeh Piryaeei^{4*}

1- Dr. F. Nabipour Pathobiology laboratory, Kerman, Iran

2- Department of Biological Sciences, Faculty of Basic Sciences, Higher Education Institute of Rab-Rashid, Tabriz, Iran

3- Molecular Medicine Department, Pasteur Institute of Iran, Tehran, Iran

4- Research Center for Molecular Medicine, School of Medicine, Hamadan University of Medical Sciences, Hamadan, Iran

Abstract

Background: Robertsonian translocations (RobTs) are one of the major chromosomal abnormalities which lead to spontaneous abortion. They occur in the human population at the rate of 1 in 1000 live infants. In this paper, a family carrying one of the rare RobTs was presented and some features of all kinds of RobTs were reviewed.

Case Presentation: A couple with a history of three miscarriages was referred to Omid Health Clinic of Hamadan, Iran. The karyotype of the woman was 45,XX,rob(14;15)(q10;q10) and she exhibited phenotypically good health. Karyotype analysis of proband's uncle and his wife with a consanguineous marriage revealed that they were both carriers of rob(14;15). This couple had six offspring, three of which were dead, and the other three were alive with a normal phenotype. Besides, this couple had an unborn child, with a karyotype of 44,XX,rob(14;15)(q10;q10).

Conclusion: These observations showed that genetic counseling, pedigree, and chromosomal analysis are needed to discover the cause of spontaneous abortion, stillbirth, congenital anomalies, sudden infant death syndrome (SIDS), *etc.* Moreover, families carrying RobTs would be offered prenatal diagnosis screening tests and, if necessary, assisted reproductive technology methods to assist with preimplantation genetic test for structural rearrangement (PGT-SR) reproduction.

Keywords: Aneuploidy, Chromosomal translocation, Genetic disorders, Infertility, Prenatal diagnosis, Spontaneous abortion.

To cite this article: Sahraeean S, Jebelli A, Shahbazi Z, Piryaeei F. Homozygosity for Robertsonian Translocation (14q;15q) in a Newborn with a Familial History of Recurrent Abortion and Newborns Affected by Hepatosplenomegaly: A Case Report. *J Reprod Infertil.* 2023;24(4):301-305. <https://doi.org/10.18502/jri.v24i4.14158>.

* Corresponding Author:
Fahimeh Piryaeei, Assistant Professor of Medical Genetics, Research Center for Molecular Medicine, School of Medicine, Hamadan University of Medical Sciences, Hamadan, Iran
E-mail:
f.piryaeei@umsha.ac.ir

Received: May 31, 2023

Accepted: Oct. 31, 2023

Introduction

Robertsonian translocations (RobTs) include fusion between two acrocentric chromosomes and are the most prevalent structural abnormality in the human population, which occur in 1/1000 of live infants. Five acrocentric chromosomes, namely 13, 14, 15, 21, and 22 are involved in this abnormality. These chromosomes have extremely short arms and do not contain any unique genes (1).

Balanced RobTs are typically identified in adults who exhibit a normal phenotype. Conversely, unbalanced RobTs are predominantly detected in children and are associated with a diverse range of clinical manifestations (2). In a RobT-balanced karyotype, there are only 45 chromosomes, including the translocated one. This translocated chromosome is formed by the fusion of the long arms of two acrocentric chromosomes (3). As a

result of the central fusion, RobT carriers can be easily detected using karyotyping (4).

Balanced chromosomal translocations are known as a cause of infertility, as they are mostly the reason for repeated miscarriages (5). Since individuals with balanced RobT karyotypes typically exhibit a normal phenotype, many of them are unaware of their genetic background. However, it's important to note that they may face potential challenges such as infertility, an increased risk of miscarriage, and the possibility of having children with abnormal karyotypes (6). Furthermore, acrocentric chromosomes are susceptible to uniparental disomy (UPD), which occurs with a prevalence of 0.6% in non-homologous RobTs and 66% in homologous RobTs. The data underscores the significant association between recurrent miscarriages and chromosomal structural abnormalities in parents, emphasizing the crucial role of these genetic factors in recurrent pregnancy losses (7).

Rob(14;15)(q10;q10) is one of ten non-homologous RobTs (3) that leads to a very uncommon structural abnormality (4). However, the segregation analysis of this translocation is of significant interest because of the effect of chromosomes 14 and 15 in developing different genetic disorders (8). The incidence of these abnormalities among couples experiencing recurrent miscarriages ranges from 3% to 8% (9). As for all acrocentric chromosomes, the UPD of chromosomes 14 and 15 leads to an abnormal phenotype. Maternal UPD for chromosome 14 manifests symptoms of mild developmental delay, short stature, and precocious puberty, whereas the consequences of paternal UPD for chromosome 14 are more severe compared with maternal one, with skeletal abnormalities, deformities, and intellectual disability. Prader-Willi syndrome is caused by maternal uniparental

disomy (UPD) of chromosome 15, whereas Angelman syndrome is caused by paternal uniparental disomy of the same chromosome (10, 11).

In this case report, a woman carrying the rob (14;15) was reported who suffered from recurrent miscarriages; further investigation is warranted in her uncle's family, as they have a history of three deceased children with splenomegaly. Besides, the relevant literature review related to all kinds of RobTs are provided in the following parts.

Case Presentation

Clinical information: The proband was a 31-year-old woman (IV-8) (Figure 1) who had a consanguineous marriage and a history of three consecutive miscarriages, and was referred to Omid Health Clinic of Hamadan, Iran in 2022. Her karyotype analysis showed 45,XX,rob(14;15) but her husband (III-3) had a normal karyotype and phenotype.

Pedigree analysis revealed her uncle (III-5) had a consanguineous marriage with six offspring, three of them (IV-4, IV-5, IV-6) passed away at approximately 10-12 months, exhibiting symptoms of hepatosplenomegaly. The surviving offspring were phenotypically normal. His wife (III-4) was pregnant at the time of the visit. After obtaining informed consent, the mentioned couple was referred for karyotype analysis because of the affected children. This study has been approved by the Ethical Committee of Hamadan University of Medical Sciences (IR.UMSHA.REC.1402.341).

Results

The proband (IV-8) had previously been diagnosed with a 45,XX,rob(14;15)(q10;q10) karyotype. High-resolution karyotyping based on GTG banding (G-bands by trypsin using Giemsa) was

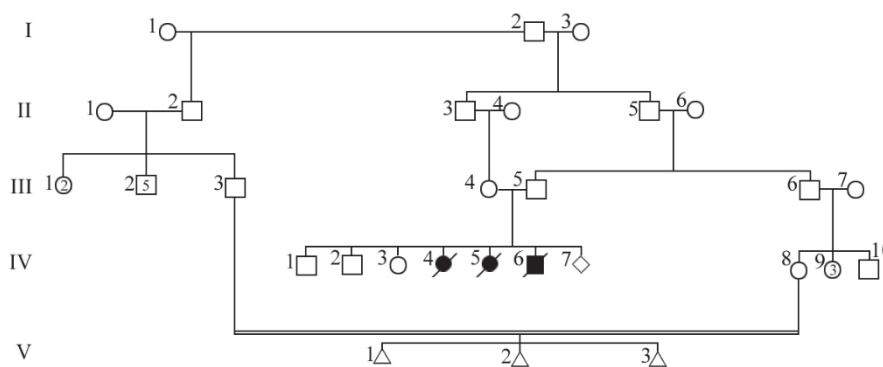

Figure 1. Family pedigree, arrow indicates the proband; solid symbols show the affected child, open symbols represent clinically asymptomatic individuals, and triangles stand for spontaneous abortions

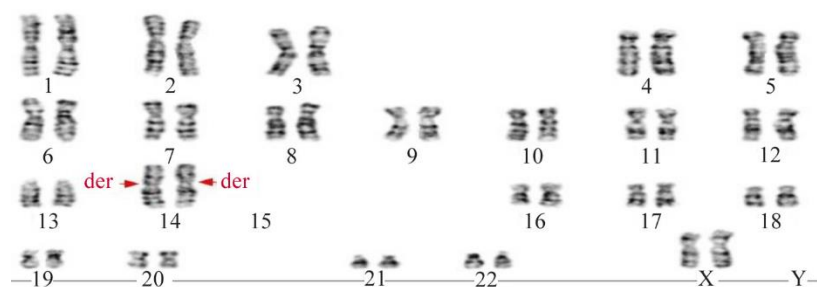

Figure 2. A karyotype image of fetal cells obtained through amniocentesis fluid revealed a chromosomal makeup of 44,XX,rob(14;15)×2

performed for the female fetus of III-4 and III-5 (using amniotic fluid as a specimen) and her parents (using a blood-heparin specimen). The ISCN (International System for Human Cytogenomic Nomenclature) results of the parent's karyotypes showed 45,XX,rob(14;15)(q10;q10) karyotype for III-4, and 45,XY,rob(14;15)(q10;q10) karyotype for III-5. Also, ISCN results indicated 44,XX,rob(14;15)×2 karyotype for the fetus (IV-7) (Figure 2).

Discussion

Acrocentric rearrangements are the most prevalent abnormalities in human population. Referring to a study performed in 2010, it was found that female carriers have a higher risk of having unbalanced offspring compared to male carriers (12). On the other hand, it has been confirmed that aneuploidy resulting from RobT is more prevalent in sperm, and it is predictable to observe infertility, miscarriages, and anomalies as a consequence (13).

Most RobTs are between non-homologous chromosomes (14). Although carriers of RobT appear to be normal (15), they are at a very high risk of having recurrent spontaneous miscarriages and children with UPD (14), congenital abnormalities, or mental retardation (12).

The case reported in this study was a heterozygous carrier of rob(14;15)(10q;10q), who had a normal phenotype. She had a consanguineous marriage and her husband was healthy with a normal karyotype. Her pedigree showed the prevalence of this chromosomal abnormality in her family, and she complained about recurrent miscarriages. Her uncle and his wife, who were first cousins, were both carriers of rob(14;15). This couple had six children, three of them were phenotypically normal, and others died due to an un-

known genetic reason. The wife was pregnant and the status of the fetus's health remained unknown. Therefore, karyotyping was performed on the parents and the fetus. The results demonstrated that the fetus's karyotype was 44,XX,rob(14;15)×2. The pregnancy was continued, and the fetus was born with a normal phenotype.

Although rob(14;15) is classified as a very rare RobT, it can cause recurrent miscarriages. A case report study in 2010 introduced a carrier female with 45,XX,rob(14;15)(q10;q10) karyotype whose medical history showed three consecutive abortions with no familial background (16). In 2020, a remarkable case was reported involving an individual with both rob(13;14) and rob(14;15), who experienced macrocytic anemia. The hypothesis of a correlation between the reduction of nuclear organization regions (NORs) and this particular type of anemia was formulated. However, further studies are needed to confirm this assumption as a fact (4).

Consistent with the aforementioned findings, our study also revealed that such translocations can potentially lead to infertility, recurrent miscarriages, stillbirth, idiopathic abnormalities, and other related conditions due to the presence of acquired trisomy 14 or trisomy 15.

Most Robertsonian translocations are commonly rob(13;14), rob(14;21), and rob(21;21), while others are infrequent. When one partner has a Robertsonian translocation and the other has a typical karyotype, six different embryo karyotypes can be produced. The likelihood of having a child with trisomy is greater when the mother carries the translocation compared to when the father is the carrier. Similar to reciprocal translocations, gametogenesis is affected by meiotic arrest, leading to a higher number of normal or balanced embryos. In couples where the male has a Robertsonian trans-

location, the chances of sustaining a pregnancy with a chromosomally abnormal embryo are lower compared to cases where the female has the translocation (17). Chromosomal analysis, when employed by OB/GYN and IVF specialists in collaboration with genetic experts or genetic counselors, serves as a valuable diagnostic method for effective reproductive guidance and treatment (18).

Conclusion

In conclusion, RobTs are significant contributors to infertility and are associated with spontaneous abortions, anomalies, and malformations. Couples experiencing recurrent miscarriages should consider genetic counseling and cytogenetic testing. In some cases, assisted reproductive techniques (ARTs) such as intrauterine insemination (IUI), IVF, and ICSI can be effective solutions. Further research is needed to gain a deeper understanding of RobTs and their impact on human fertility and health. Couples experiencing recurrent miscarriages should strongly consider genetic counseling and cytogenetic testing to assess the presence of such translocations. Assisted reproductive techniques (ARTs) like IUI, IVF, and ICSI can be valuable options for couples affected by RobTs. These methods can help overcome the challenges posed by these chromosomal rearrangements. Continued research into RobTs and their effects on human health, especially fertility, is essential for advancing our understanding and improving clinical approaches to address these genetic abnormalities.

Acknowledgement

We thank the family members who provided samples and clinical information for this study.

Funding: This research has been funded by Hamadan University of Medical Sciences, Hamadan, Iran (Grant number: 140205103646).

Conflict of Interest

The authors declare that they have no competing interests.

References

1. Song J, Sun L, Xu S, Liu N, Yao Y, Liu Z, et al. A family with Robertsonian translocation: a potential mechanism of speciation in humans. *Mol Cytogenet.* 2016;9:48.
2. Tunç E, Ilgaz S. Robertsonian translocation (13; 14) and its clinical manifestations: a literature review. *Reprod Biomed Online.* 2022;45(3):563-73.
3. Wiland E, Olszewska M, Woźniak T, Kurpisz M. How much, if anything, do we know about sperm chromosomes of Robertsonian translocation carriers? *Cell Mol Life Sci.* 2020;77(23):4765-85.
4. Sasi R, Senft J, Spruill M, Rej S, Perrotta PL. Double robertsonian translocations in an infertile patient with macrocytic anemia: a case report. *Mol Cytogenet.* 2020;13:14.
5. Vozdova M, Oracova E, Kasikova K, Prinosilova P, Rybar R, Horinova V, et al. Balanced chromosomal translocations in men: relationships among semen parameters, chromatin integrity, sperm meiotic segregation and aneuploidy. *J Assist Reprod Genet.* 2013;30(3):391-405.
6. Huang S, Juneau K, Bogard PE, Davies KA, Wang ET, Kingsley CB, et al. Identifying Robertsonian translocation carriers by microarray-based DNA analysis. *Fetal Diagn Ther.* 2016;40(1):59-62.
7. Soltani N, Mirzaei F, Ayatollahi H. Cytogenetic studies of 608 couples with recurrent spontaneous abortions in northeastern Iran. *Iran J Pathol.* 2021;16(4):418-25.
8. Moradkhani K, Puechberty J, Bhatt S, Lespinasse J, Vago P, Lefort G, et al. Rare robertsonian translocations and meiotic behaviour: sperm FISH analysis of t (13; 15) and t (14; 15) translocations: a case report. *Hum Reprod.* 2006;21(12):3193-8.
9. Kocaaga A, Kilic H, Gulec S. The pattern of chromosomal abnormalities in recurrent miscarriages: a single center retrospective study. *Ann Saudi Med.* 2022;42(6):385-90.
10. Shaffer LG, Agan N, Goldberg JD, Ledbetter DH, Longshore JW, Cassidy SB. American college of medical genetics statement on diagnostic testing for uniparental disomy. *Genet Med.* 2001;3(3):206-11.
11. Kim SR, Shaffer LG. Robertsonian translocations: mechanisms of formation, aneuploidy, and uniparental disomy and diagnostic considerations. *Genet Test.* 2002;6(3):163-8.
12. Ko DS, Cho JW, Lee HS, Kim JY, Kang IS, Yang KM, et al. Preimplantation genetic diagnosis outcomes and meiotic segregation analysis of robertsonian translocation carriers. *Fertil Steril.* 2013;99(5):1369-76.
13. Rogenhofer N, Dürl S, Ochsenkühn R, Neusser M, Aichinger E, Thaler C, et al. Case report: elevated sperm aneuploidy levels in an infertile Robertsonian translocation t (21; 21) carrier with possible

- interchromosomal effect. *J Assist Reprod Genet.* 2012;29(4):343-6.
14. Kovaleva NV, Shaffer LG. Under-ascertainment of mosaic carriers of balanced homologous acrocentric translocations and isochromosomes. *Am J Med Genet Part A.* 2003;121(2):180-7.
 15. Acar H, Yildirim MS, Çora T, Ceylaner S. Evaluation of segregation patterns of 21; 21 Robertsonian translocation along with sex chromosomes and interchromosomal effects in sperm nuclei of carrier by FISH technique. *Mol Reprod Dev.* 2002;63(2):232-6.
 16. Venkateshwari A, Srilekha A, Sunitha T, Pratibha N, Jyothy A. A Robertsonian Translocation rob (14;15)(q10: q10) in a patient with recurrent abortions: a case report. *J Reprod Infertil.* 2010;11(3):197-200.
 17. Katagiri Y, Tamaki Y. Genetic counseling prior to assisted reproductive technology. *Reprod Med Biol.* 2021;20(2):133-43.
 18. Poornima S, Daram S, Devaki RK, Qurratulain H. Chromosomal abnormalities in couples with primary and secondary infertility: Genetic counseling for assisted reproductive techniques (ART). *J Reprod Infertil.* 2020;21(4):269-74.